

MANUAL INTERNAL LINE-UP CLAMP

Model 242-W

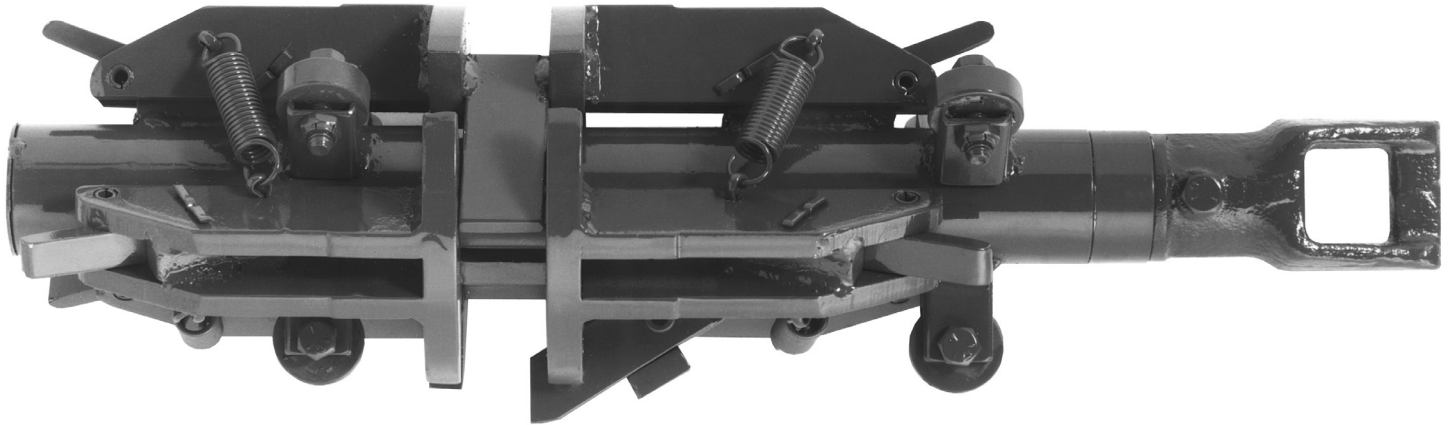

The Model 242-W Sawyer Internal Line-up Clamp is a field-proven alternative to more expensive pneumatic type clamps. The Model 242-W is a wedge type, manual line-up clamp available in 6 and 8 inch (152.4mm & 203.2mm) ID for use in distribution, gathering systems and other small size pipeline work.

The Model 242-W is available in copper, stainless steel or carbon steel construction with your choice of hard or soft wheels. Self-positioning, the Model 242-W is simple to use and easily maintained in the field... simply insert the clamp and hand crank to expand the screw wedge alignment tool. The Line-up Clamp comes standard with a hand crank, 47-foot (14.3m) sectional rod (to be welded together on-site as needed) and an end hook.

Features:

- Available in 6" and 8" (152.4mm & 203.2mm) Pipe ID Sizes
- Copper, Stainless Steel or Carbon Steel Construction
- Choice of Hard or Soft Wheels
- Self Positioning, Simple to Use
- Comes Standard with 47' (14.3m) Hand Crank
- Built for Rugged Use, Easily Maintained
- Field Proven Design Since 1952



*Sawyer products are sold exclusively through distributors in the U.S. and abroad.
Please contact us for the name of your nearest distributor.*

MANUAL INTERNAL LINE-UP CLAMP

Model 242-W

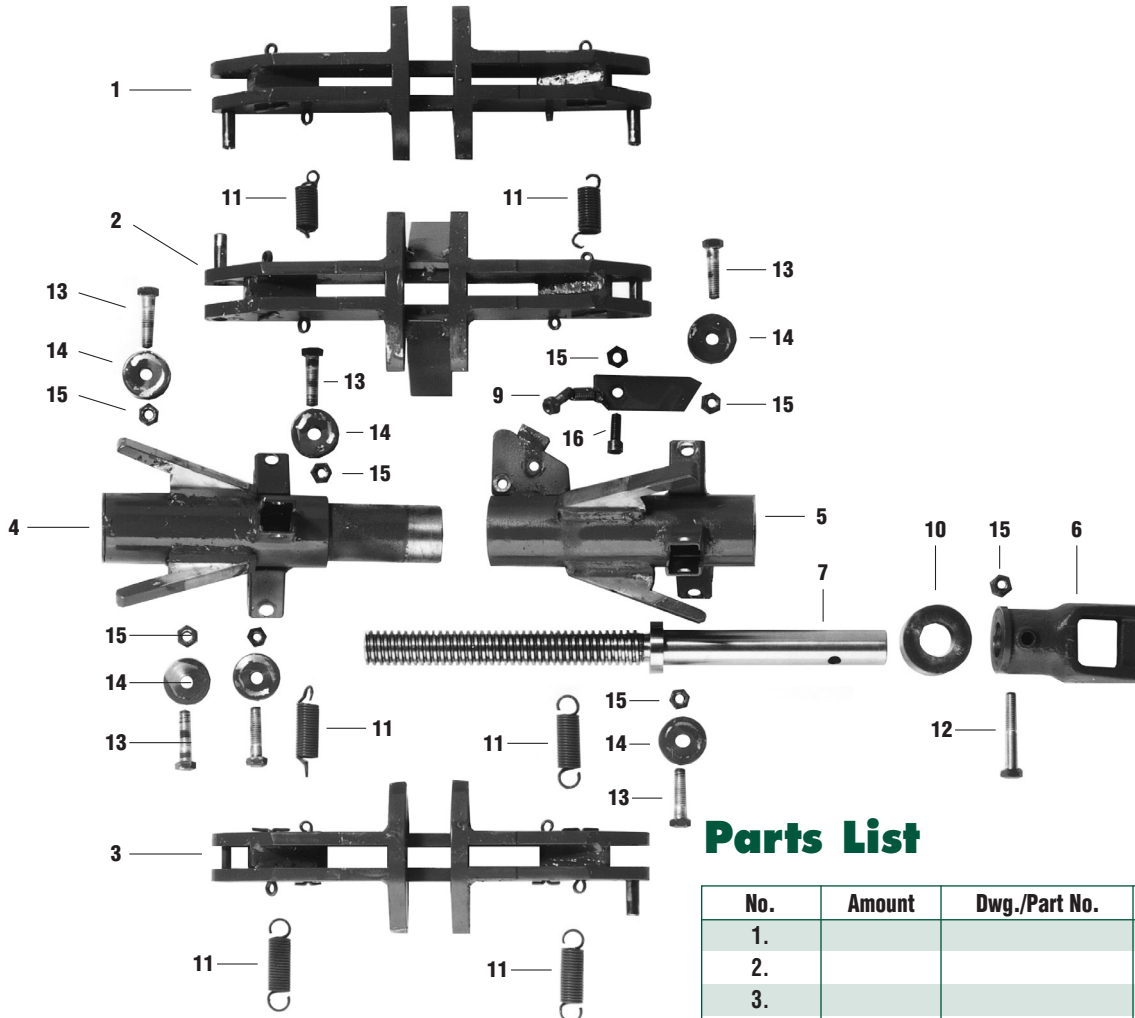

Parts List

No.	Amount	Dwg./Part No.	Description/Name
1.			
2.			
3.			
4.			
5.			
6.			
7.			
8.			
9.			
10.			
11.			
12.			
13.			
14.			
15.			
16.			



SAWYER MFG. COMPANY

1031 N. Columbia Place • Tulsa, Oklahoma 74110 U.S.A.

Phone: (918) 834-2550 • Fax: (918) 834-0318

E-Mail: info@sawyermfg.com

Web Site: www.sawyermfg.com

SETTING THE STANDARD FOR PIPELINE AND WELDING EQUIPMENT SINCE 1948

©2007 Sawyer Manufacturing Company, Rev. 8/07, Printed in U.S.A.