

"COMPACT" PIPE CUTTING AND BEVELING MACHINES

Model 200C

Specifications

Machine Number	Pipe Size		Weight	
	in	mm	lb	kg
1	3 - 8	76.2 - 203.2	38	17.2
2	8 - 14	203.2 - 355.6	40	18.1
3	14 - 20	355.6 - 508.0	50	22.7
4	22 - 26	558.8 - 660.4	60	27.2
5	26 - 30	660.4 - 762.0	83	37.6
6	30 - 36	762.0 - 914.4	90	40.8
7	38 - 42	965.2 - 1066.8	140	63.5
8	44 - 48	1117.6 - 1219.2	152	68.9



Setting and Operating Instructions

All compact Pipe Cutting and Beveling Machines are set up and operated in generally the same manner.

1. Consult the spacer chart (in box with spacers) for the correct spacer and screw spacers in place. Spacers should be tightened but not overly tight.
2. Mount machine on pipe. Release boomer and either set machine over the end of the pipe or crank the ring around until the smaller segment lines up with the open end of the frame. Release the latch, swing the ring open and set the machine over the pipe. Close and latch the ring.
3. Adjust the boomer by hooking the boomer hook to the boomer eye, leaving the boomer in the open or wide position. Then, connect the swivel snap to the correct link that offers the least amount of slack in the chain. Snap the boomer closed and the machine is mounted. This adjustment is only necessary when changing pipe sizes.
4. Adjust the torch holder for the correct angle, lead and clearance.

Operation

For best results in flame cutting/beveling, the torch should be lighted and cranked around the line to be cut. This will remove loose scale and other impurities that may interrupt the cut, also, lightly preheating the section to be cut. Then start at the top of the pipe and crank the torch back and forth to preheat, blow through, crank clockwise on around the pipe.

If pipe is not round, use the Model 281 Out-of-Round Torch Carrier, standard on No. 3 machines and larger.

For cutting out welds, the double bevel attachment allows use of two torches and cuts both bevels simultaneously.

When using the electric motorized kit, preheating is done by switching the unit from forward to reverse and back and forth until ready to cut. Then, turn on oxygen for cutting and proceed to cut. Control should be on forward position when cutting. Correct selection of tip, gas pressure, equipment maintenance, and right torch speed will guarantee a high quality cut/bevel.



Sawyer products are sold exclusively through distributors in the U.S. and abroad. Please contact us for the name of your nearest distributor.

MODEL 200C "COMPACT" PIPE CUTTING AND BEVELING MACHINES

Model 200C

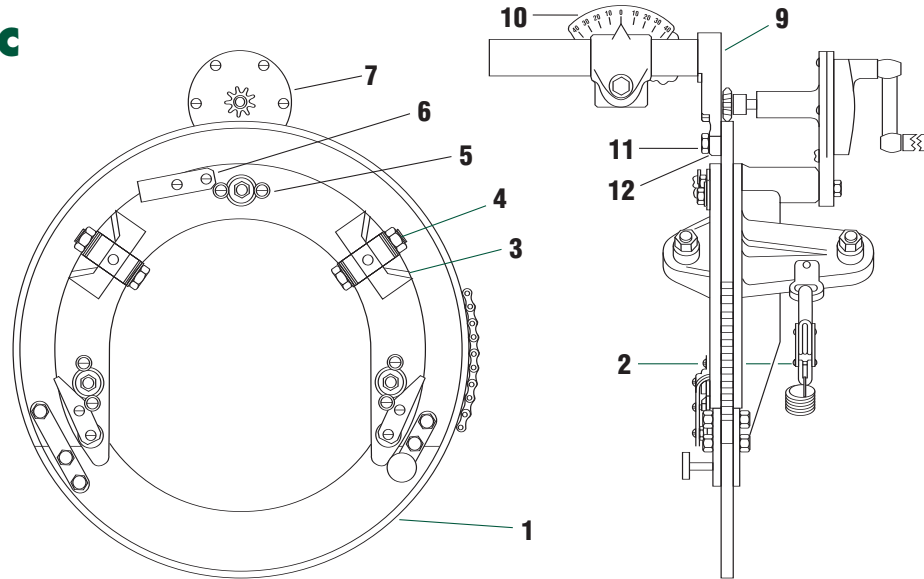

Parts List

Machine Number:		1		2		3		4		5		6		7		8	
No.	Description	Assy.No.	Qty.	Assy.No.	Qty.	Assy.No.	Qty.	Assy.No.	Qty.	Assy.No.	Qty.	Assy.No.	Qty.	Assy.No.	Qty.	Assy.No.	Qty.
1	Traveling Ring Assy.	24L-1	1	24L-2	1	24L-3	1	24L-4	1	24L-5	1	24L-6	1	24L-7	1	24L-8	1
2	Boomer Assy.	49A-1	1	49A-2	1	49A-3	1	49A-4	1	49A-5	1	49A-6	1	49A-7	1	49A-8	1
3	Frame	24AK-C	1	24AM-C	1	24EC	1	24C1-1	1	30608	1	24BH1-C	1	24BM	1	24BK	1
4	Spacer/Bushing Assy.	30C-1	4	30C-1	4	30C-1	4	30C-1	4	30C-1	4	30C-1	4	30C-1	4	30C-1	4
5	Roller Bushing Assy. - Fixed	54C-1	2	54C-1	2	54C-1	2	54C-1	2	54C-1	2	54C-1	2	54C-1	2	54C-1	2
	Roller Bushing Assy. - Eccentric	54D-1	1	54D-1	1	54D-1	1	54D-1	1	54D-1	1	54D-1	3	54D-1	3	54D-1	3
6	Thrust Bearing Assy. - Straight	4F1-S	1	4F1-S	1	4F1-S	1	4F1-S	1	4F1-S	1	4F1-S	2	4F1-S	2	4F1-S	2
	Thrust Bearing Assy. - R.H.	4F1-R	1	4F1-R	1	4F1-R	1	4F1-R	1	4F1-R	1	4F1-R	1	4F1-R	1	4F1-R	1
	Thrust Bearing Assy. - L.H.	4F1-L	1	4F1-L	1	4F1-L	1	4F1-L	1	4F1-L	1	4F1-L	1	4F1-L	1	4F1-L	1
7	Gear Box Assy.	251-A	1	251-A	1	251-A	1	251-A	1	251-A	1	251-A	1	251-A	1	251-A	1
8	Torch Holder/Carrier Assy. (9,10,11,12)	44D-1	1	44D-1	1	281	1	281	1	281	1	281	1	281	1	281	1
9	Torch Bracket	42BA-1	1	42BA-1	1	42BA-1	1	42BA-1	1	42BA-1	1	42BA-1	1	42BA-1	1	42BA-1	1
10	Torch Clamp Assy.	44DI-A	1	44DI-A	1	44DI-A	1	44DI-A	1	44DI-A	1	44DI-A	1	44DI-A	1	44DI-A	1
11	Torch Bracket Capscrew	120-105	2	120-105	2	120-105	2	120-105	2	120-105	2	120-105	2	120-105	2	120-105	2
12	Washer	131004	4	131004	4	131004	4	131004	4	131004	4	131004	4	131004	4	131004	4
13	Spacer Set - Not Shown		1		1		1		1		1		1		1		1
14	Double Cut A.H. - Not Shown - Optional	283	1														
15	Elec. Motor Drive - Not Shown - Optional - Spec. Machine Size																



SAWYER MFG. COMPANY

1031 N. Columbia Place • Tulsa, Oklahoma 74110 U.S.A.

Phone: (918) 834-2550 • Fax: (918) 834-0318

E-Mail: info@sawyerfmfg.com

Web Site: www.sawyerfmfg.com

SETTING THE STANDARD FOR PIPELINE AND WELDING EQUIPMENT SINCE 1948

©2007 Sawyer Manufacturing Company, Rev. 8/07, Printed in U.S.A.