

PARTS LIST - BEVELING TRANSMISSION - MODEL 206A

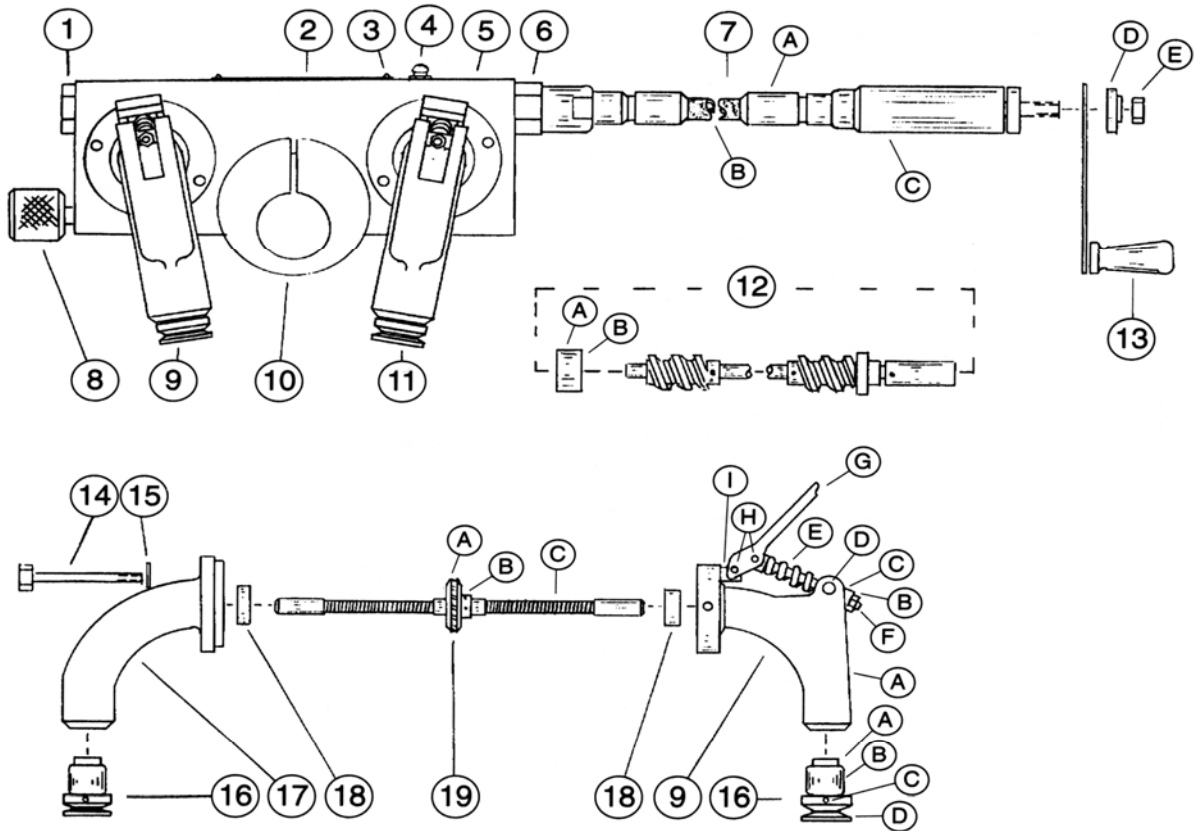

No	PART NAME	PART No	QTY
1	End Plug	32G-1	1
2	Name Plate	55G	1
3	Drive Screw	515-3	2
4	Grease Fitting	518-1	1
5	Body	11H-1	1
6	Connector	93B-1	1
7	Main Flex Drive Shaft Assy	29CA	1
7a	Outer Housing Assy	209CA-1	1
7b	Inner Core Assy	29CA-2	1
7c	Hand Piece	29CA-3	1
7d	Washer	29CA-6	1
7e	Nut	29CA-7	1
8	Set Screw Assy	4DF	1
9	Rear Leg Assy Complete	4DD-1	1
9a	Ball Leg Assy - Rear	4FL-R	1
	Latch Sub Assy (incl 9b - 9j)	4FH	1
9b	Nut	517-6	1
9c	Spacer	30R-1	1
9d	Pivot Pin	35AG	1
9e	Spring	51AO	1
9f	Latch Pin - Long	38D-1	1
9g	Latch Handle	33H-1	1
9h	Rivit	523-2	2

No	PART NAME	PART No	QTY
9i	Latch Pin - Short	38C-1	1
9j	Hex Jam Nut (Not Shown)	517-32	1
10	Torch Holder	94A-1	1
11	Ball Leg Assy - Front	4DD-2	1
12	Worm Shaft Assy	4DA	1
12a	Bearing Housing - Rear	56N	1
12b	Bearing	505-21	2
13	Crank Handle Assy	4DE	1
14	Cap Screw	519-13	4
15	Washer	502-29	4
16	Drive Wheel Assy	4DB	4
16a	Bearing Race	79C-1	1
16b	Bearing	505-19	1
16c	Pin	522-6	1
16d	Wheel	64N-1	1
17	Flanged Leg - Rear	96A-1	1
18	Worm Gear Shaft Bearing	505-20	4
19	Worm Gear Shaft Assy	4DC	2
19a	Worm Gear	37AF	1
19b	Set Screw	515-4	2
19c	Flex Shaft	29CK	1
20	Flanged Leg - Front (Not Shown)	96A-2	1